

CORRECTED VERSION

(19) World Intellectual Property Organization
International Bureau



(43) International Publication Date
30 November 2000 (30.11.2000)

PCT

(10) International Publication Number
WO 00/71032 A3

- (51) International Patent Classification⁷: A61B 17/00
- (21) International Application Number: PCT/US00/12030
- (22) International Filing Date: 2 May 2000 (02.05.2000)
- (25) Filing Language: English
- (26) Publication Language: English
- (30) Priority Data: 09/304,254 3 May 1999 (03.05.1999) US
- (71) Applicant and
(72) Inventor: SAINES, Marius [US/US]; 4560 Admiralty Way, Suite 356, Marina Del Rey, CA 90292 (US).
- (74) Agents: FARBER, Michael, B. et al.; Oppenheimer Wolff & Donnelly LLP, Suite 3800, 2029 Century Park East, Los Angeles, CA 90067-3024 (US).
- (81) Designated States (national): AE, AG, AL, AM, AT, AU, AZ, BA, BB, BG, BR, BY, CA, CH, CN, CR, CU, CZ, DE, DK, DM, DZ, EE, ES, FI, GB, GD, GE, GH, GM, HR, HU, ID, IL, IN, IS, JP, KE, KG, KP, KR, KZ, LC, LK, LR, LS, LT, LU, LV, MA, MD, MG, MK, MN, MW, MX, NO, NZ, PL, PT, RO, RU, SD, SE, SG, SI, SK, SL, TJ, TM, TR, TT, TZ, UA, UG, US, UZ, VN, YU, ZA, ZW.
- (84) Designated States (regional): ARIPO patent (GH, GM, KE, LS, MW, SD, SL, SZ, TZ, UG, ZW), Eurasian patent (AM, AZ, BY, KG, KZ, MD, RU, TJ, TM), European patent (AT, BE, CH, CY, DE, DK, ES, FI, FR, GB, GR, IE, IT, LU, MC, NL, PT, SE), OAPI patent (BF, BJ, CF, CG, CI, CM, GA, GN, GW, ML, MR, NE, SN, TD, TG).
- Published: — with international search report
- (88) Date of publication of the international search report: 11 January 2001
- (48) Date of publication of this corrected version: 18 April 2002
- (15) Information about Correction: see PCT Gazette No. 16/2002 of 18 April 2002, Section II
- For two-letter codes and other abbreviations, refer to the "Guidance Notes on Codes and Abbreviations" appearing at the beginning of each regular issue of the PCT Gazette.



WO 00/71032 A3

(54) Title: HEMOSTATIC DEVICE FOR ANGIOPLASTY

(57) Abstract: A hemostatic device for sealing blood vessels, particularly for use in angioplasty comprises: (1) a barrel including: (a) a cylindrical portion; and (b) a terminal tapered portion, the terminal tapered portion being divided by at least one slot cut therein so that the tapered portion expands radially when force is applied to it; and (iii) an aperture at the narrow end of the terminal tapered portion; (b) a proteinaceous powder in the cylindrical portion of the barrel, the proteinaceous powder including at least one protein that promotes hemostasis in a blood vessel, the aperture in the terminal tapered portion being for flow of the proteinaceous powder; and (c) a plunger inserted into the barrel, the plunger including: (i) a narrow portion including therein means for guiding a guidewire; and (ii) a conical portion extending from the narrow portion so that, when the plunger is inserted into the barrel, the large end of the conical portion is located closest to the tapered portion of the barrel. The proteinaceous powder can be fibrin, thrombin, or fibrinogen. In use, the device is inserted into the tissue in the vicinity of an artery during the performance of angioplasty over a guidewire and leaves a plug in the tissue to seal the artery.

HEMOSTATIC DEVICE FOR ANGIOPLASTY

5

BACKGROUND OF THE INVENTION

10 The present invention is directed to a device for promoting sealing of blood vessels, particularly for use in angioplasty.

 Angioplasty is an increasingly common surgical procedure, particularly for treatment of circulatory and cardiovascular disorders. Angioplasty involves the insertion of
15 arterial catheters (which range between 5F and 9F). This requires the advancement of appropriate catheters over guidewires (which are in the range of 0.035 inches or 0.089 cm in diameter). At the present time, following removal of the catheter, bleeding at the arterial insertion site is stopped by application of a 5 pound pressure bag, use of manual compression, or application of a clamp to the limb of the patient for a period of time. All of these procedures are inefficient and
20 painful. Furthermore, these procedures risk the occurrence of hematoma in the patient.

 Among the devices that have been used for sealing arterial punctures such as those made during angioplasty are those described in U.S. Patent No. 5,830,130, to Janzen et al., U.S. Patent No. 5,527,292 to Adams et al., U.S. Patent No. 5,843,051 to Adams et al., U.S.
25 Patent No. 5,649,959 to Hannam et al., U.S. Patent No. 5,540,715 to Katsaros et al., U.S. Patent No. 5,129,822, to Weldon et al., U.S. Patent No. 5,221,259 to Weldon et al., U.S. Patent No. 5,292,332 to Lee, and U.S. Patent No. 5,443,481 to Lee, the disclosures of which are herein incorporated in their entirety by this reference.

30 Although these patents disclose a variety of approaches for sealing puncture wounds in arteries such as those generated by angioplasty, there is still a need for an improved approach to seal such puncture wounds. There is a need for a device that is painless and is more effective than existing devices and procedures for sealing such wounds. There is further a need

for improved procedures and devices that reduce the risk of hematoma formation in such devices and procedures.

SUMMARY

5

An improved device for promoting hemostasis subsequent to angioplasty or other procedures that requires the puncturing of a blood vessel meets these needs. In general, the device comprises:

(1) a barrel including:

10

(a) a cylindrical portion; and

(b) a terminal tapered portion, the terminal tapered portion being divided by at least one slot cut therein so that the tapered portion expands radially when force is applied to it; and

(c) an aperture at the narrow end of the terminal tapered portion;

15

(2) a proteinaceous powder in the cylindrical portion of the barrel, the proteinaceous powder including at least one protein that promotes hemostasis in a blood vessel, the aperture in the terminal tapered portion being for flow of the proteinaceous powder; and

(3) a plunger inserted into the barrel, the plunger including:

20

(a) a narrow portion including therein means for guiding a guidewire; and

(b) a conical portion extending from the narrow portion so that, when the plunger is inserted into the barrel, the large end of the conical portion is located closest to the tapered portion of the barrel.

25

Typically, the proteinaceous powder includes a protein selected from the group consisting of fibrinogen, fibrin, and thrombin.

30

Typically, the length of the barrel is about 1.5 cm and the diameter of the cylinder is about 0.3 cm. Typically, the means for guiding the guidewire is a channel in which the guidewire is inserted. Preferably, the channel has a diameter of about 0.5 mm.

Another aspect of the present invention is a method for sealing a blood vessel comprising:

(1) inserting the device of the present invention along a guidewire so that the terminal tapered portion enters the tissue in the vicinity of the blood vessel;

(2) pushing down the plunger to force the proteinaceous powder into the tissue in the vicinity of the blood vessel;

(3) removing the guidewire; and

(4) withdrawing the device from the tissue in the vicinity of the blood vessel to
5 leave proteinaceous material in the tissue to assist hemostasis.

BRIEF DESCRIPTION OF THE DRAWINGS

The following invention will become better understood with reference to the
10 specification, appended claims, and accompanying drawings, where: (to be inserted)

Figure 1 is a side view of a hemostasis device according to the present invention;

Figure 2 is a cross-sectional view of the device shown in Figure 1 along the line
2-2';

Figure 3 is a cross-sectional view of the device shown in Figure 1 along the line
15 3-3';

Figure 4 is a side view of the device of Figure 1 shown in a partially expanded
configuration during its use; and

Figure 5 is a side view of the device of Figure 1 at the conclusion of its use.

20 DESCRIPTION

An improved hemostatic device for angioplasty meets these needs. In general, the
device is a modified syringe as shown in Figures 1-4. The device contains a proteinaceous
powder that promotes clotting. As used herein, the term "powder" includes both amorphous
25 powders and crystalline powders, including crystalline proteins.

The device is shown in Figure 1. The device 100 includes a barrel 102. The barrel
102 includes a cylindrical portion 104 and a tapered portion 106. The tapered portion 106 is
divided by at least one slot 108. The slot 108 is cut into the tapered portion 106 so that the
30 tapered portion 106 expands radially when force is applied to it. More than one slot 108 can be
used.

The cylindrical portion 104 of the barrel 102 also includes a proteinaceous
powder 110. The proteinaceous powder 110 includes at least one protein that promotes

nemostasis in a blood vessel. The proteinaceous powder 110 can also fill all or part of the cylindrical portion 104 of the barrel 102.

5 The tapered portion 106 of the barrel 102 also includes an aperture 111 for flow of the proteinaceous powder therethrough. The aperture 111 is at the narrow end of the tapered portion 106 of the barrel 102.

10 The device further includes a plunger 112 inserted into the barrel 102. The plunger 112 includes a narrow portion 114 including therein means 116 for guiding a guidewire 118. The means 116 is typically a channel in which the guidewire 118 can be inserted. The plunger 112 further includes a conical portion 120 extending from the narrow portion 114. The conical portion 120 extends from the narrow portion 114 in an arrangement so that when the plunger 112 is inserted into the barrel 102, the large end 122 of the conical portion 120 is located closest to the tapered portion of the barrel 102. The conical portion 120 helps to penetrate the skin and the subcutaneous tissue and helps to compress the inner material.

15

Typically, the proteinaceous powder includes at least one of the proteins fibrinogen, fibrin, or thrombin. A suitable preparation of fibrin is Tisseel fibrin sealant manufactured by Baxter Health Care Corporation. A suitable preparation of crystalline fibrinogen is a preparation known as Avitene produced by Med Chem Products, Inc.

20

Other proteins that stimulate clotting can be used.

Preferably, the length of the barrel is about 1.5 cm. Also, preferably, the diameter of the cylinder is about 0.3 cm. These dimensions can be adjusted as needed to adapt a device to deliver different volumes of proteinaceous powder and for use in different applications. The diameter of 0.3 cm was chosen based on the average size of the skin incision for arterial puncture. The height of 1.5 cm was based on the average distance between the skin and the arterial wall.

25

30

The diameter of the central channel in which the guidewire can be inserted is typically 0.5 mm. The diameter of this channel is chosen to accommodate a typical guidewire.

In use, the device 100 is inserted along the guidewire 118 so that the terminal tapered portion 106 of the barrel 102 enters the tissue in the vicinity of the blood vessel. The guidewire 118 is the guidewire that was used for the insertion of the catheter. The guidewire 118 is then removed and the plunger 112 is pushed down to force the proteinaceous powder 110 into the tissue in the vicinity of the blood vessel. After about 20 minutes, the device is withdrawn. This leaves proteinaceous material in the tissue in the vicinity of the blood vessel as a plug to assist hemostasis. A dressing can then be applied to the area. The dressing is typically a standard surgical dressing such as is normally used to close puncture wounds.

Further details of the device are shown in Figures 2, 3, 4, and 5. Figure 2 shows a cross-section of the device 100 along the line 2-2' in Figure 1 toward the top of the barrel 102 showing the channel 116 for the insertion of the guidewire 118. Figure 3 shows a cross-section of the device 100 along the line 3-3' through the conical portion 120 of the plunger 112.

Figure 4 shows the device 100 in a side view at a stage where the terminal tapered portion 106 of the barrel 102 is expanding radially during use. Figure 5 shows the device 100 after the plunger 112 has been pushed in to expel the proteinaceous powder 110.

ADVANTAGES OF THE INVENTION

The present invention provides an improved method of sealing blood vessels, particularly arteries, which have been opened as a result of surgical procedures such as angioplasty. The device provides more efficient sealing of these blood vessels, and reduces the pain suffered by the patient and the risk of hematoma formation. The device seals the hole rapidly by the insertion of material that forms a plug. The use of this device obviates a necessity for applying a five pound pressure bag, manual compression, or a clamp. The device can be adapted for the delivery of various volumes of clotting agents and for use in various applications.

Although the present invention has been described with considerable detail, with reference to certain preferred versions thereof, other versions and embodiments are possible. Therefore, the scope of the invention is determined by the following claims.

I claim:

1. A device for sealing a blood vessel comprising:

(a) a barrel including:

5

(i) a cylindrical portion; and

(ii) a terminal tapered portion, the terminal tapered portion being divided by at least one slot cut therein so that the tapered portion expands radially when force is applied to it; and

(iii) an aperture at the narrow end of the terminal tapered portion;

10

(b) a proteinaceous powder in the cylindrical portion of the barrel, the proteinaceous powder including at least one protein that promotes hemostasis in a blood vessel, the aperture in the terminal tapered portion being for flow of the proteinaceous powder; and

(c) a plunger inserted into the barrel, the plunger including:

15

(i) a narrow portion including therein means for guiding a guidewire; and

(ii) a conical portion extending from the narrow portion so that, when the plunger is inserted into the barrel, the large end of the conical portion is located closest to the tapered portion of the barrel.

20

2. The device of claim 1 wherein the proteinaceous powder includes a protein selected from the group consisting of fibrinogen, fibrin, and thrombin.

3. The device of claim 2 wherein the protein is fibrinogen.

4. The device of claim 2 wherein the protein is fibrin.

25

5. The device of claim 2 wherein the protein is thrombin.

6. The device of claim 1 wherein the length of the barrel is about 1.5 cm.

30

7. The device of claim 1 wherein the diameter of the cylinder is about 0.3 cm.

8. The device of claim 1 wherein the means for guiding the guidewire is a channel in which the guidewire can be inserted.

9. The device of claim 8 wherein the diameter of the channel is about 0.5 mm.

10. A method for sealing a blood vessel comprising:

- (a) inserting the device of claim 1 along a guidewire so that the terminal tapered
5 portion enters the tissue in the vicinity of the blood vessel;
- (b) pushing down the plunger to force the proteinaceous powder into the tissue;
- (c) removing the guidewire; and
- (d) withdrawing the device from the tissue in the vicinity of the blood vessel to
10 leave proteinaceous material in the tissue to assist hemostasis.

10

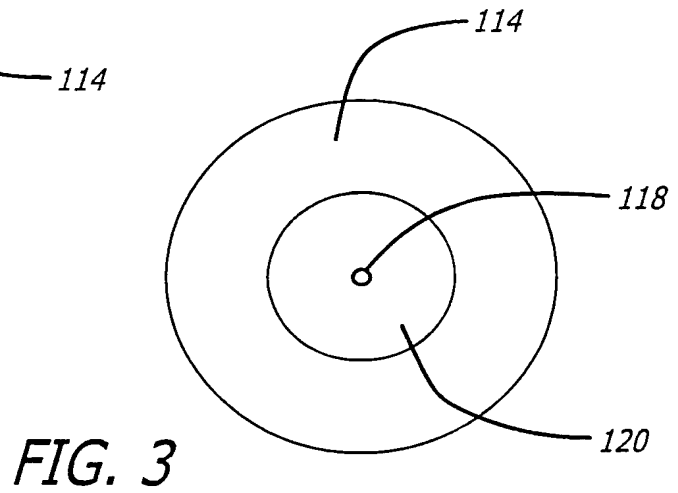
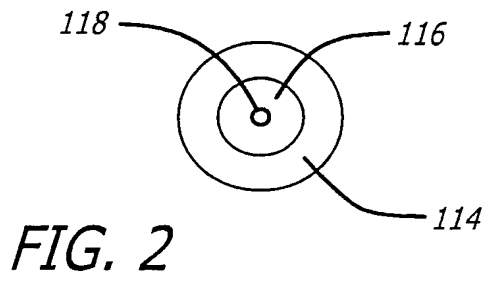
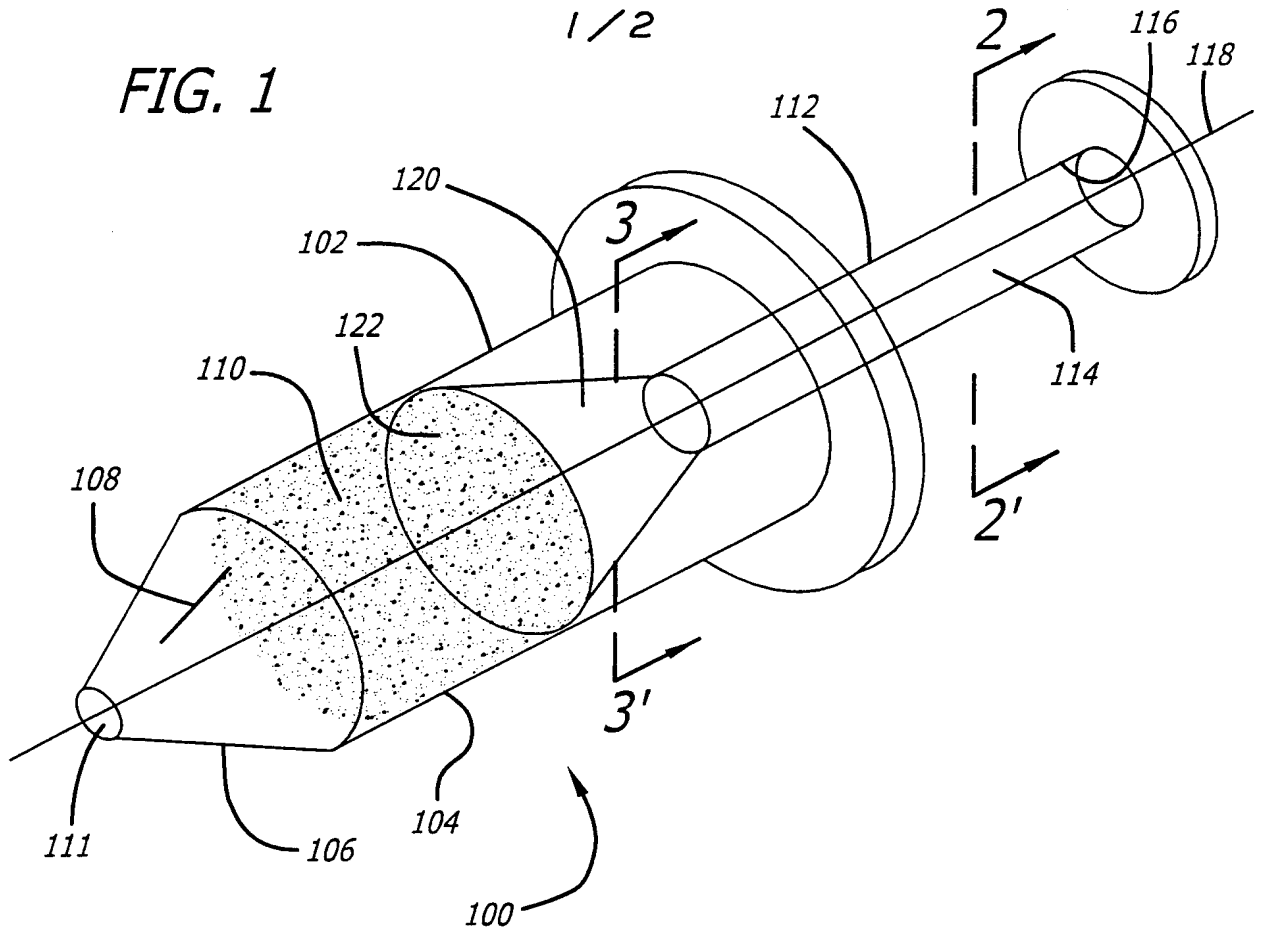

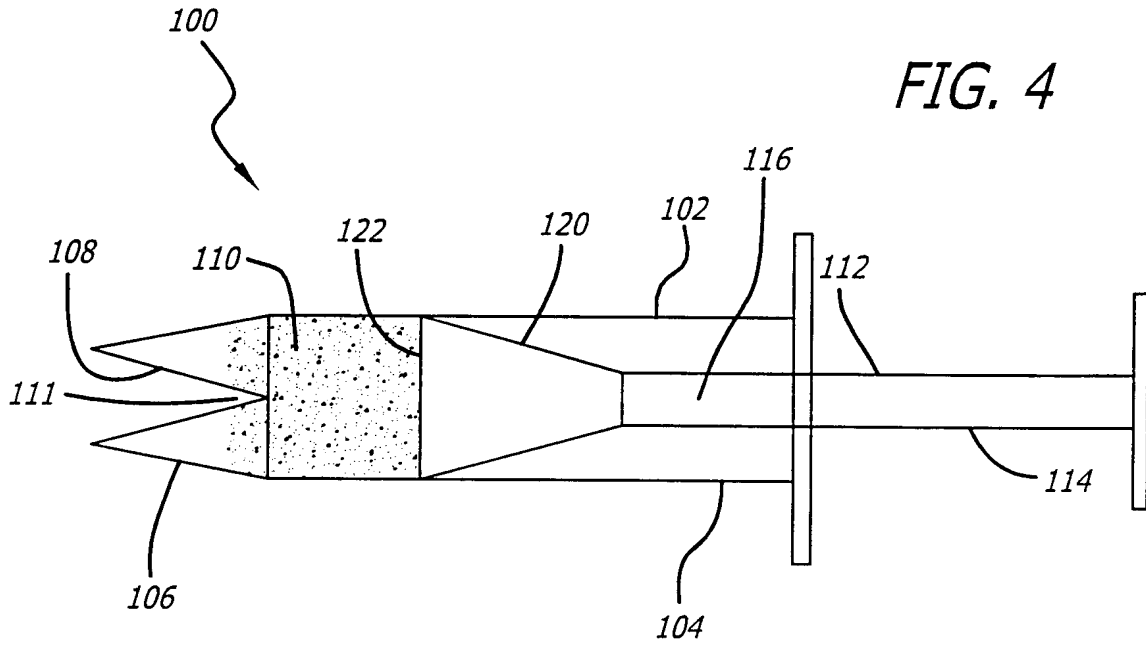

FIG. 4

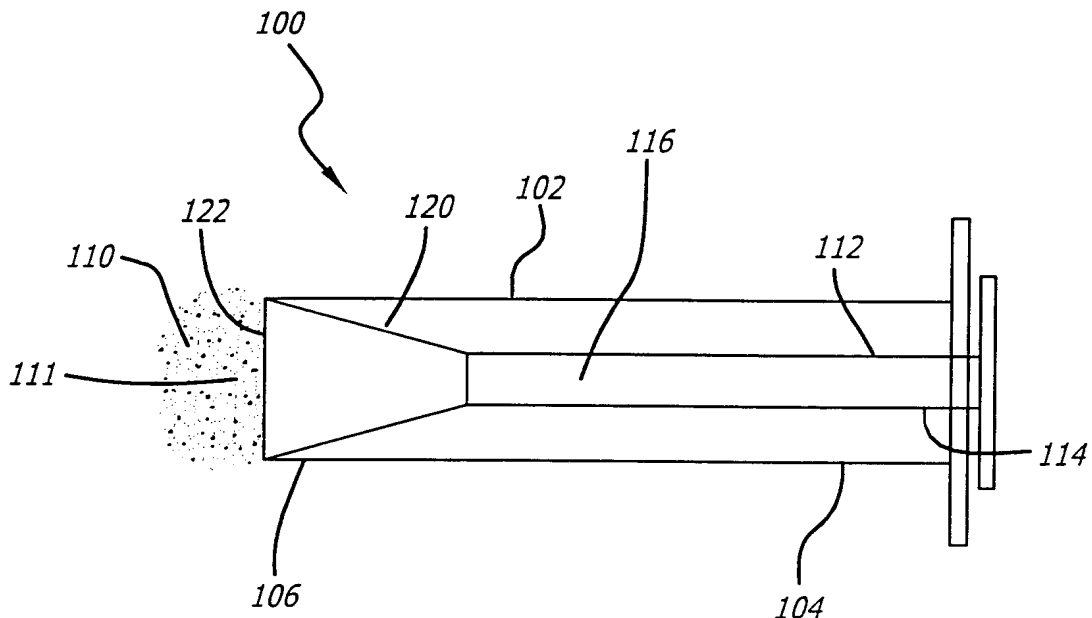

FIG. 5

INTERNATIONAL SEARCH REPORT

International Application No
PCT/US 00/12030

A. CLASSIFICATION OF SUBJECT MATTER
IPC 7 A61B17/00

According to International Patent Classification (IPC) or to both national classification and IPC

B. FIELDS SEARCHED

Minimum documentation searched (classification system followed by classification symbols)
IPC 7 A61B A61M

Documentation searched other than minimum documentation to the extent that such documents are included in the fields searched

Electronic data base consulted during the international search (name of data base and, where practical, search terms used)

EPO-Internal

C. DOCUMENTS CONSIDERED TO BE RELEVANT

Category *	Citation of document, with indication, where appropriate, of the relevant passages	Relevant to claim No.
Y	US 5 320 639 A (RUDNICK JAMES J) 14 June 1994 (1994-06-14) the whole document ---	1-9
Y	DE 33 25 622 A (MAERZ PETER;POSTEL JUERGEN) 31 January 1985 (1985-01-31) abstract; figure 6 ---	1-9
A	WO 95 08951 A (HEMODYNAMICS) 6 April 1995 (1995-04-06) abstract; figure 19 ---	1-9
A	GB 1 173 433 A (TYTE E H) 10 December 1969 (1969-12-10) the whole document ---	1
-/--		

Further documents are listed in the continuation of box C.

Patent family members are listed in annex.

* Special categories of cited documents :

- *A* document defining the general state of the art which is not considered to be of particular relevance
- *E* earlier document but published on or after the international filing date
- *L* document which may throw doubts on priority claim(s) or which is cited to establish the publication date of another citation or other special reason (as specified)
- *O* document referring to an oral disclosure, use, exhibition or other means
- *P* document published prior to the international filing date but later than the priority date claimed

- *T* later document published after the international filing date or priority date and not in conflict with the application but cited to understand the principle or theory underlying the invention
- *X* document of particular relevance; the claimed invention cannot be considered novel or cannot be considered to involve an inventive step when the document is taken alone
- *Y* document of particular relevance; the claimed invention cannot be considered to involve an inventive step when the document is combined with one or more other such documents, such combination being obvious to a person skilled in the art.
- *&* document member of the same patent family

Date of the actual completion of the international search

31 October 2000

Date of mailing of the international search report

16/11/2000

Name and mailing address of the ISA
European Patent Office, P.B. 5818 Patentlaan 2
NL - 2280 HV Rijswijk
Tel. (+31-70) 340-2040, Tx. 31 651 epo nl,
Fax: (+31-70) 340-3016

Authorized officer

Hansen, S

INTERNATIONAL SEARCH REPORT

International Application No
PCT/US 00/12030

C.(Continuation) DOCUMENTS CONSIDERED TO BE RELEVANT

Category *	Citation of document, with indication, where appropriate, of the relevant passages	Relevant to claim No.
A	US 4 986 820 A (FISCHER DAN E) 22 January 1991 (1991-01-22) abstract; figure 5 -----	1

INTERNATIONAL SEARCH REPORT

Information on patent family members

International Application No

PCT/US 00/12030

Patent document cited in search report		Publication date	Patent family member(s)	Publication date
US 5320639	A	14-06-1994	AU 6405394	26-09-1994
			WO 9420028	15-09-1994
DE 3325622	A	31-01-1985	WO 8500524	14-02-1985
			EP 0148931	24-07-1985
WO 9508951	A	06-04-1995	AU 7921494	18-04-1995
			US 5383899	24-01-1995
			US 5529577	25-06-1996
			US 5653730	05-08-1997
			US 5665106	09-09-1997
			US 5665107	09-09-1997
			US 5843124	01-12-1998
			US 5759194	02-06-1998
GB 1173433	A	10-12-1969	NONE	
US 4986820	A	22-01-1991	AU 640668	02-09-1993
			AU 5857790	17-01-1991
			CA 2063410	24-12-1990
			EP 0478661	08-04-1992
			WO 9100114	10-01-1991